

# Vent Covers

**VC0001**

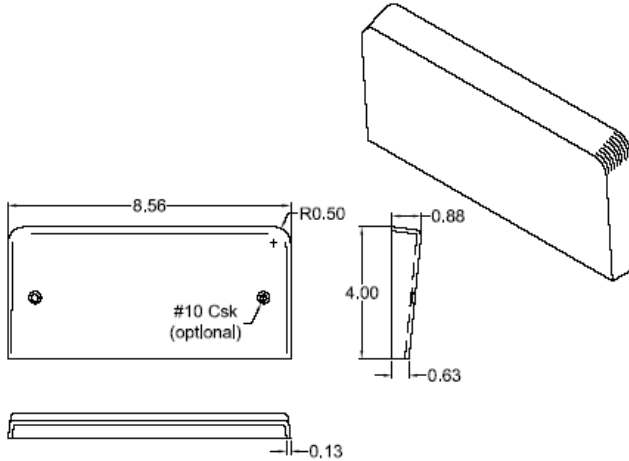

**VC0001**

**Vent Cover**

- 1) Finish: 120 grit ground and brushed.
- 2) Designed to weld on, but can be supplied with 2 #10 countersunk holes for tie down screws or no holes.

**VC0002**

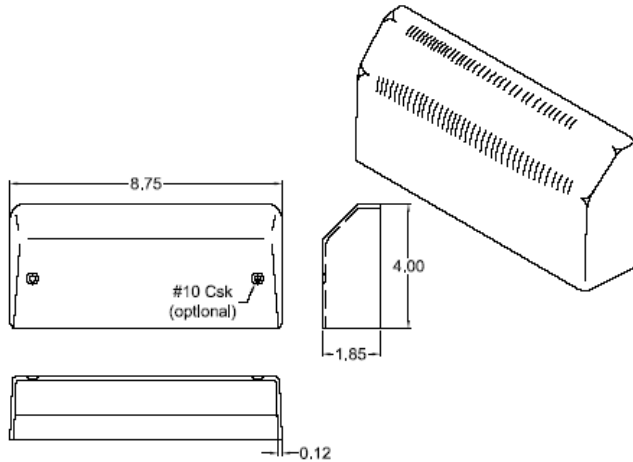

**VC0002**

**Vent Cover**

- 1) Finish: 120 grit ground and brushed.
- 2) Designed to weld on, but can be supplied with 2 #10 countersunk holes for tie down screws or no holes.

**VC0003**

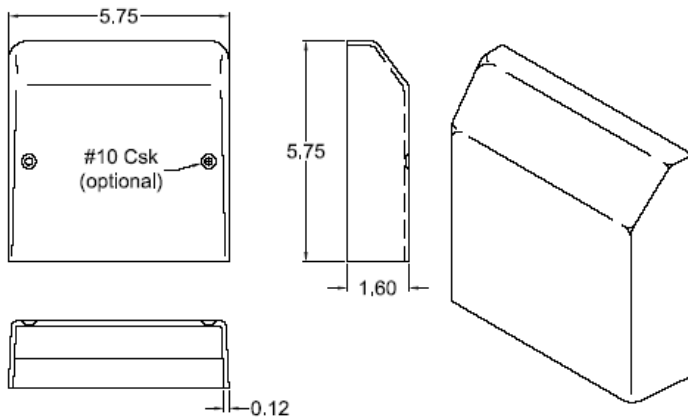

**VC0003**

**Vent Cover**

- 1) Finish: 120 grit ground and brushed.
- 2) Designed to weld on, but can be supplied with 2 or 4 #10 countersunk holes for tie down screws or no holes.

**VC0004**

**VC0004**

**Vent Cover**

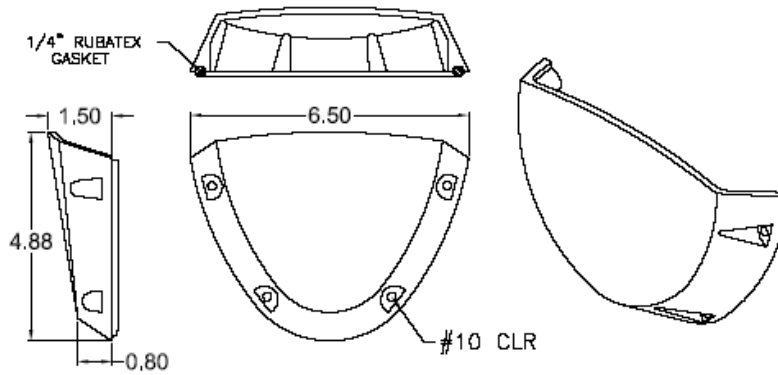

- 1) Finish: bright polished or bead-blasted.
- 2) Designed to cover the holes cut for venting of the module body or engine compartments (hood).

**VC0007**

**VC0007**

**Intake Vent Cover**

- 1) Finish: ball-burnished.

