

SP2017

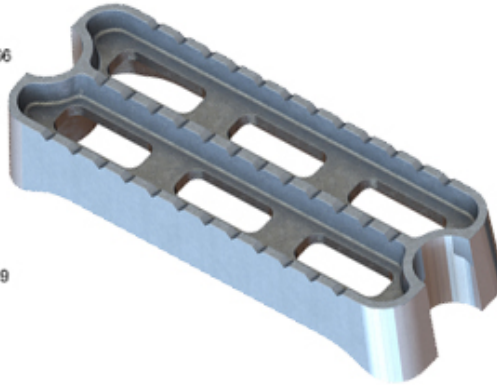
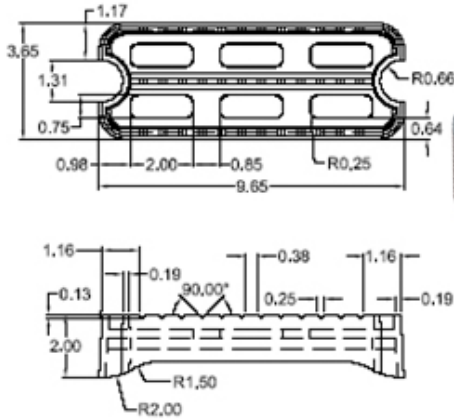

SP2017 Rear Ladder Step

- 1) Finish: All outside surfaces are polished.
- 2) Raised "Open" tread design.

SP2024

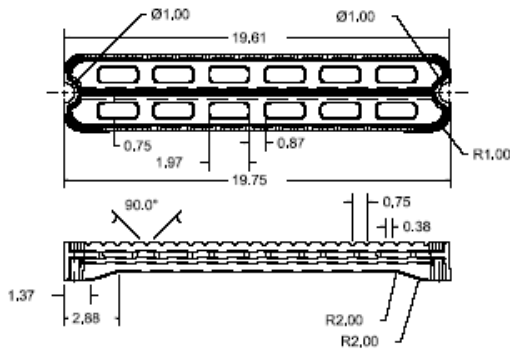

SP2024 Ladder Step w/ Raised Tread

- 1) Finish: ball-burnished

SP2025

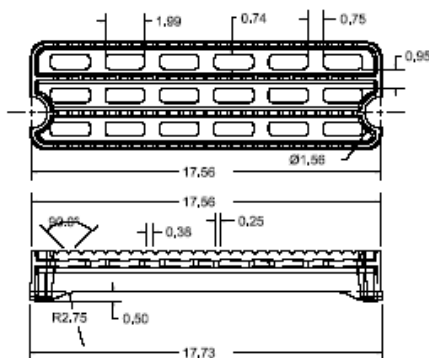

SP2025 Ladder Step w/ Raised Tread

- 1) Finish: wheel-a-brated

SP2029

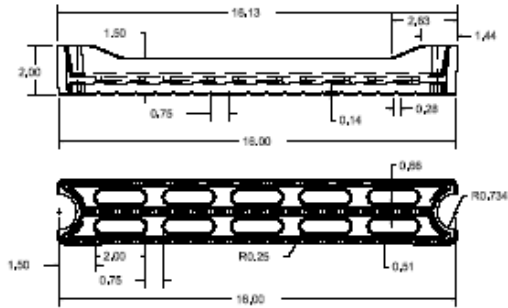

SP2029 Ladder Step w/ Raised Tread

1) Finish: ball-burnished

SP2030

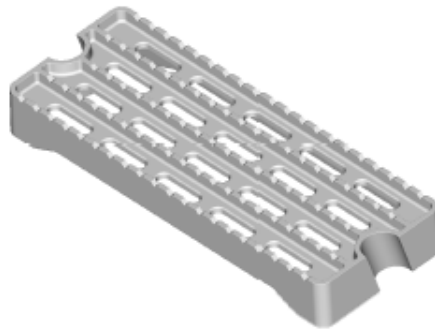
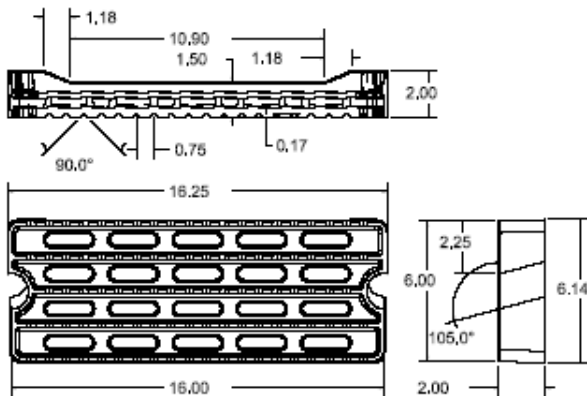

SP2030 Ladder Step w/ Raised Tread

1) Finish: ball-burnished

SP2032

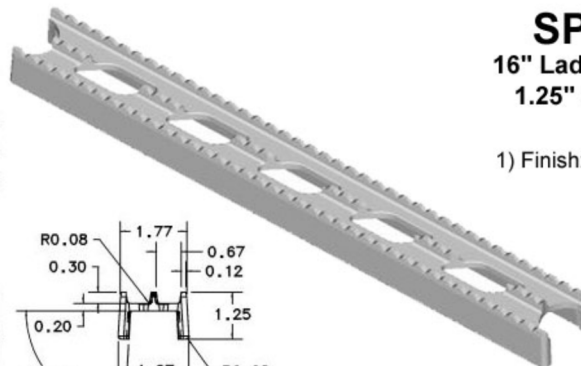
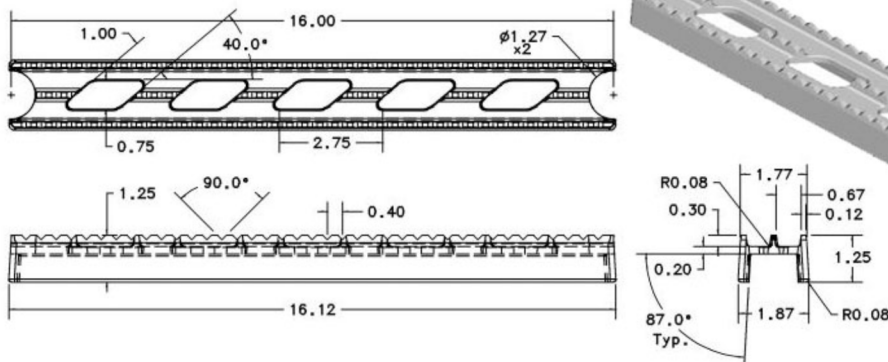

SP2032 16" Ladder Step for 1.25" OD tubing

1) Finish: ball-burnished.

SP2034

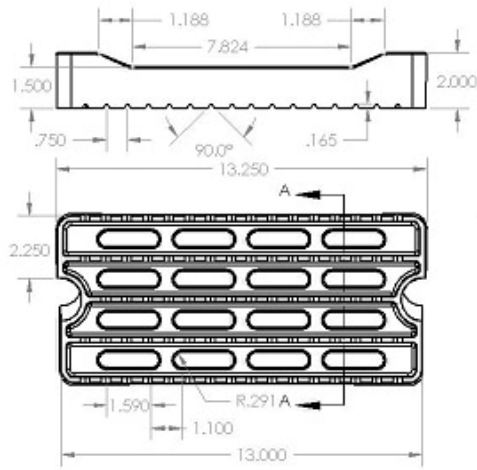

SP2034-1 13" Ladder Step w/ Raised Tread. 15d. Angle

1)Finish: Ball-burnished w/ sides
and end polished

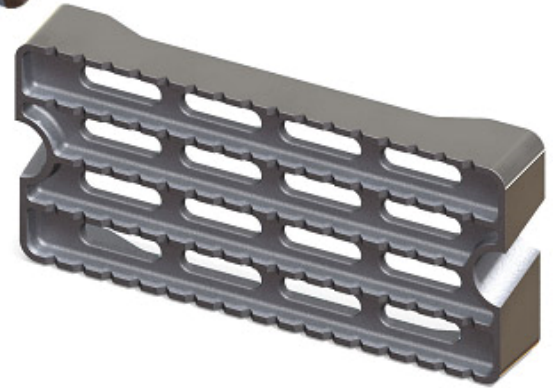

SP2035

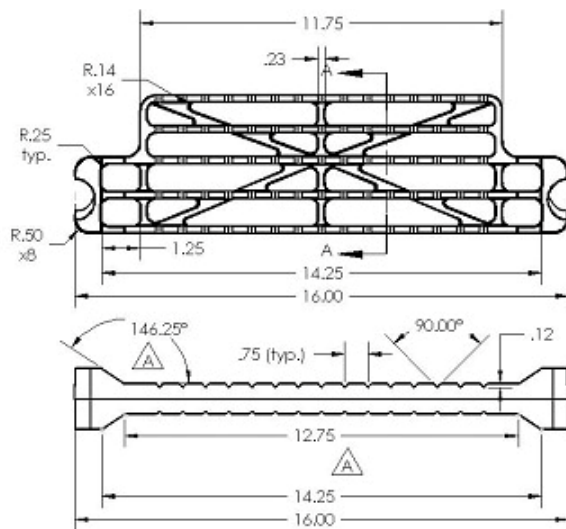

SP2035-5 16" Ladder Step

1)Finish: Ball-burnished w/ sides
and end polished

SP2036

SP2036-5 15" x 2.0" Ladder Step

- 1) Finish: Ball-burnished.
- 2) For bolting to 2" wide extrusion or welding underneath

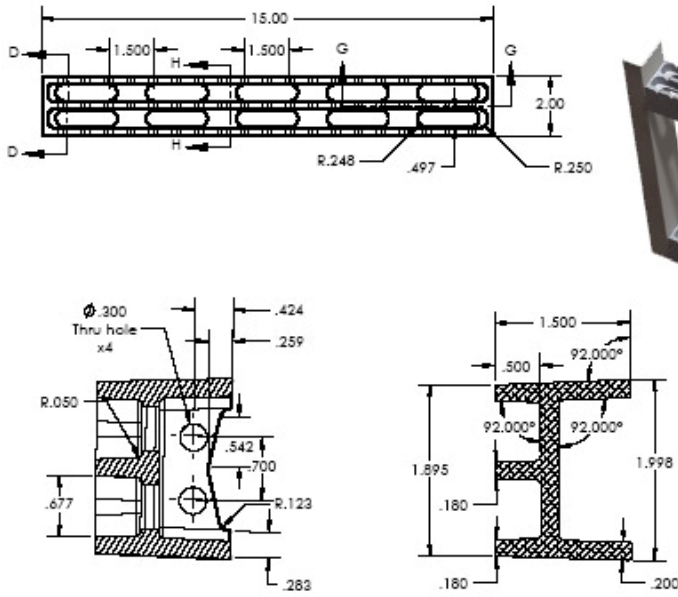

SP2041

SP2041-5 12.00" x 3.875" Ladder Step

- 1) Finish: Ball-burnished.
- 2) For bolting or welding underneath

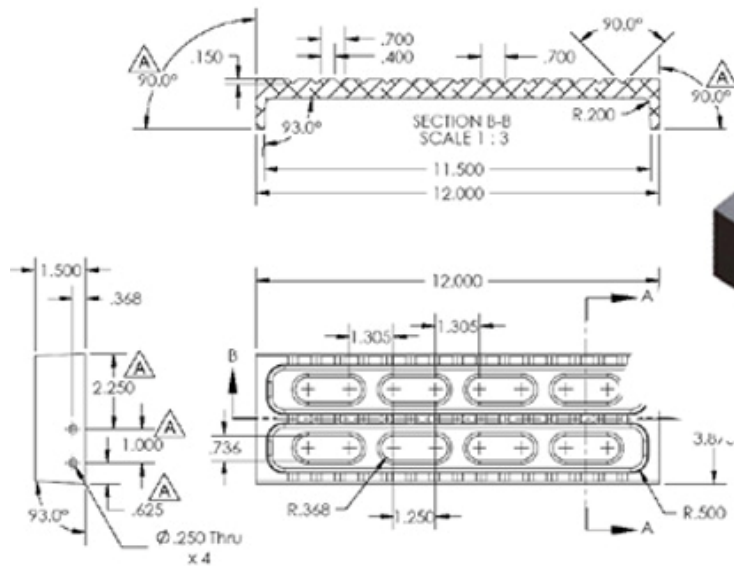

SP2042

SP2042-5 15.00" x 3.875" Ladder Step

- 1) Finish: Ball-burnished.
- 2) For bolting or welding underneath

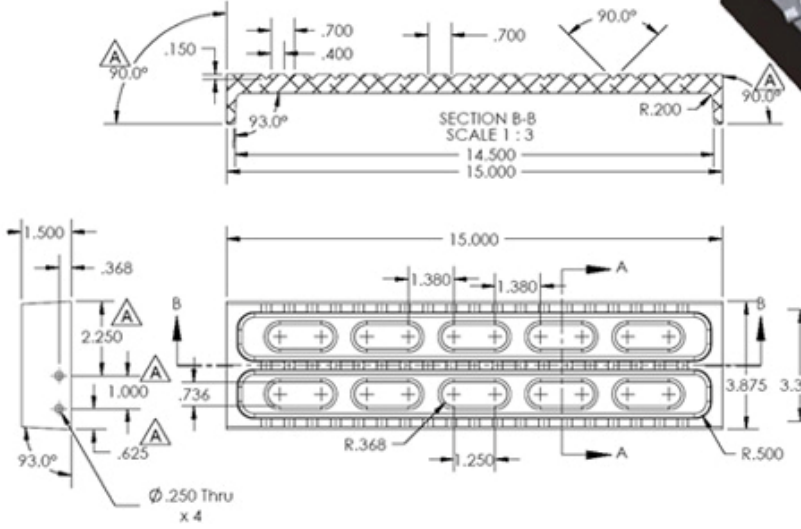
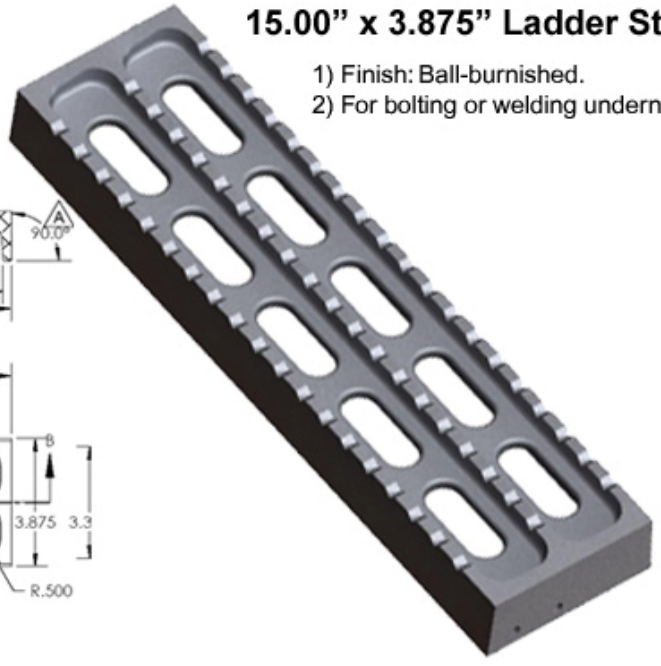

SP2043

SP2043-5 13.5" x 2.50" wide, Ladder Step w/ Raised Tread

- 1) Finish: Ball-burnished.
- 2) For bolting or welding underneath

