

TMC0090

**TMC0090-4**  
**Wheel Chock and Holder Assembly**

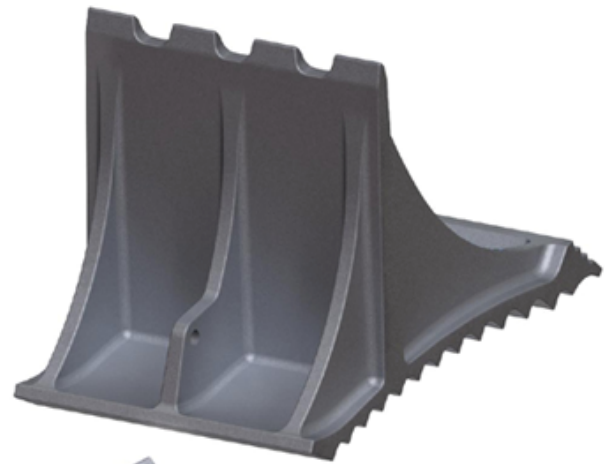

- 1) Finish: wheel-a-brated.
- 2) Mounting base has spring loaded retainer, for mounting vertical as well as horizontal.

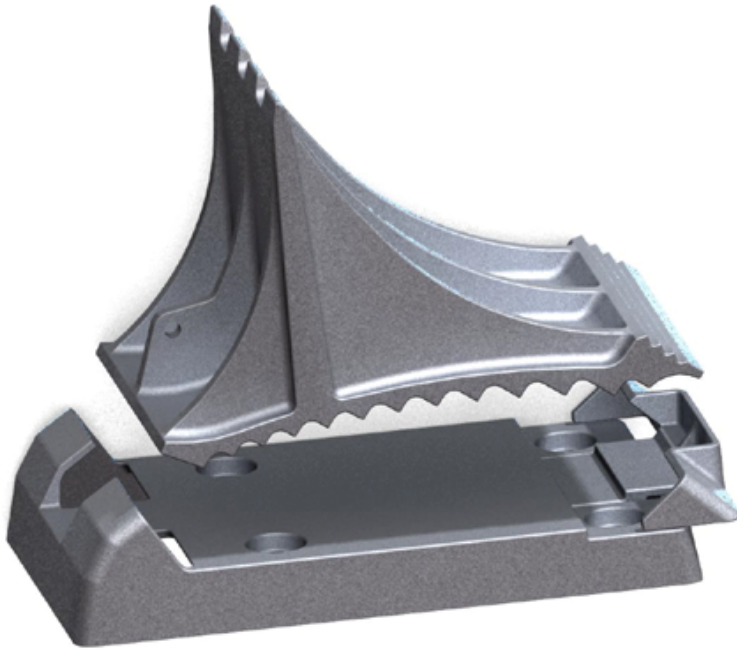